

Side assembly

(Chassis no. L7011109 & earlier)

To remove

1 Remove the rear-seat cushion

See *CVRearSeat.pdf*

2 Remove the rear-seat backrest

3 Remove the side trim

See *CVSideTrim.pdf*

Note

Save the washers from the spoiler mountings as these will be needed in the fitting of a new spoiler (where applicable).

4 ~~Remove~~ the nut from the front securing stud.

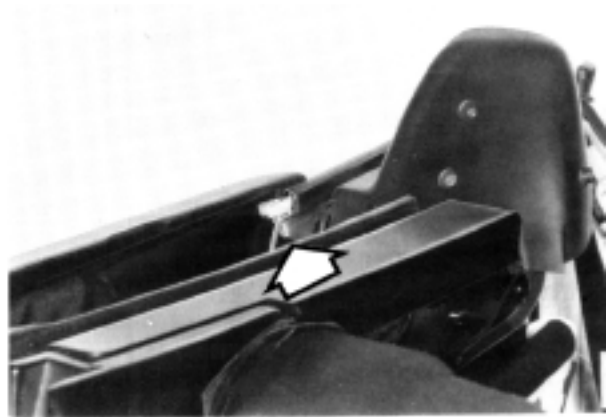

5 Open the top halfway and remove the nut from the middle stud.



6 Remove the wing nut from the rear fastening (access through the flap in the trim inside the luggage compartment).

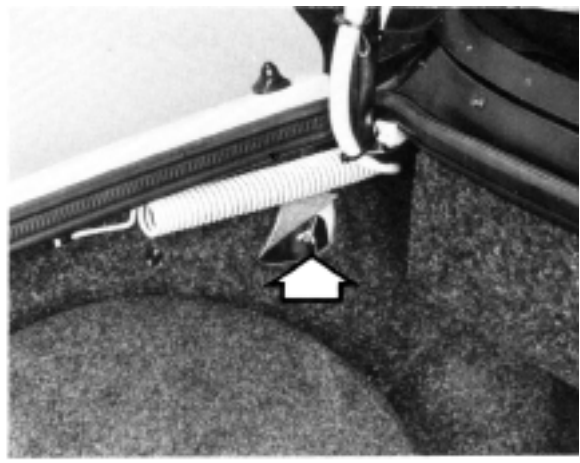

7 Use a heat gun to release the tape. Take care not to apply too much heat as this can damage the paintwork or spoiler assembly.

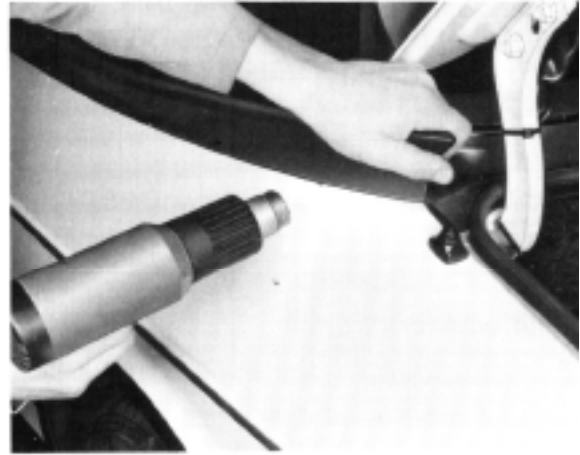

Caution

The spoiler assembly must be eased off gently to prevent the paintwork being damaged.

8 Carefully lift off the spoiler assembly.

9 Save the cable in the rear mounting hole as this will be needed in the fitting of a new spoiler assembly (where applicable).

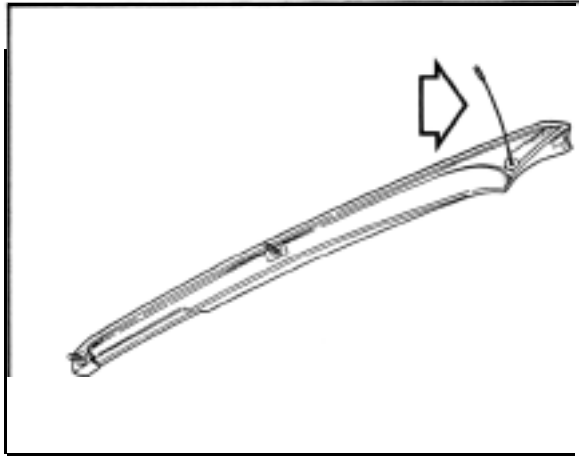

To fit

1 Carefully remove all traces of adhesive and dirt from the paintwork.

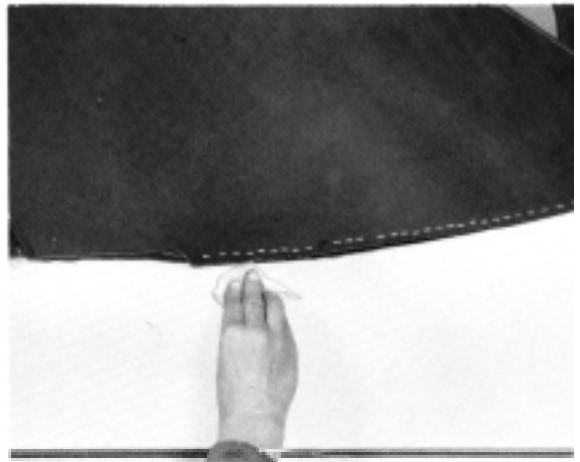

- 2 Remove all traces of old adhesive and dirt from the spoiler assembly.



- 3 Fit double-sided adhesive tape, part no. 78 74 662, along the spoiler.

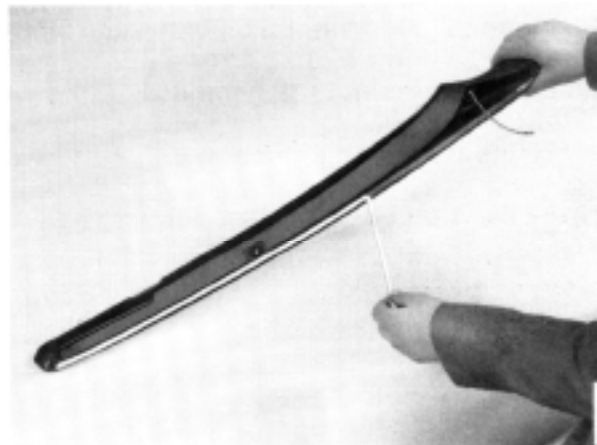

- 4 Make sure that the rubber washers and cable at the rear fastening are in place.

If a new spoiler assembly is being fitted, the rubber washers and cable must be transferred to the new one.

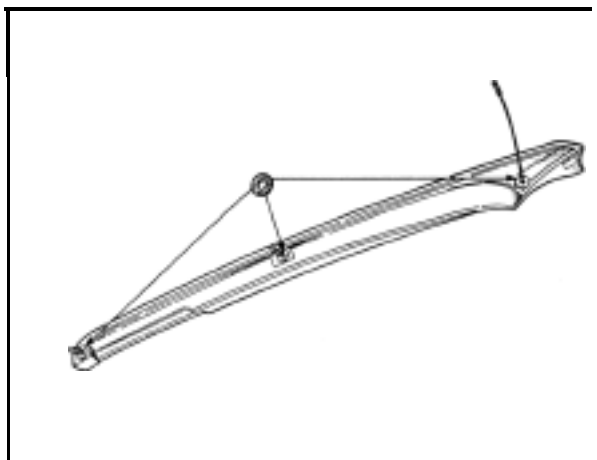

- 5 Position the spoiler assembly on the car and screw down tight the wing nut on the rear stud.

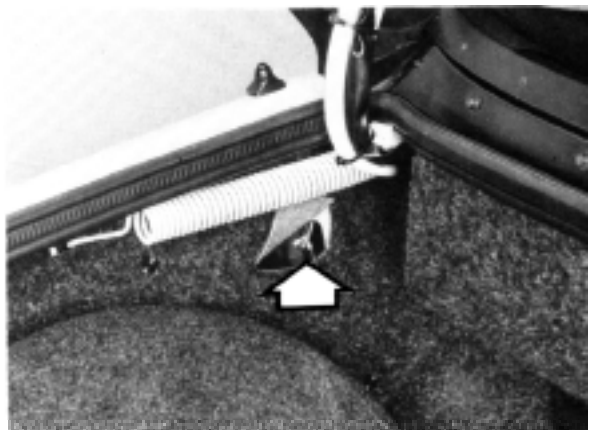

6 Fit and tighten the nut on the middle stud.



7 Fit and tighten the nut on the front stud.

8 Fit the side trim (see page 851-2).

9 Fit the backrest (see page 852-2).

10 Fit the seat cushion (see page 852-1).

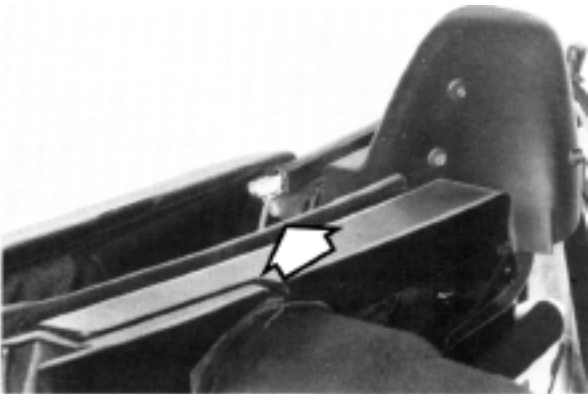

Chassis no. L701110 onwards

To remove

Note
Save the washers from the spoiler mountings as these will be needed in the fitting of a new spoiler (where applicable).

1 Remove the front securing nut.

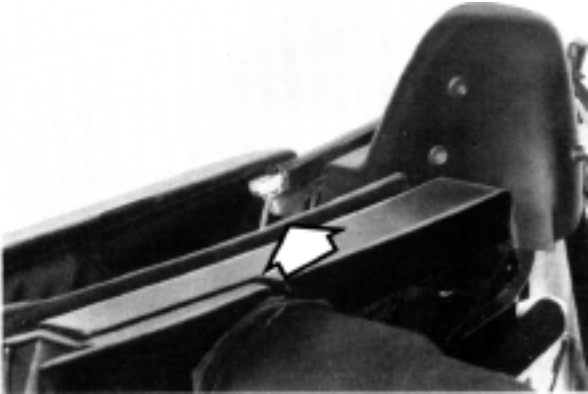

- 2 Remove the wing nut from the rear fastening (access through the flap in the trim inside the luggage compartment).



- 3 Use a heat gun to release the tape. Take care not to apply too much heat as this can damage the paintwork or spoiler assembly.

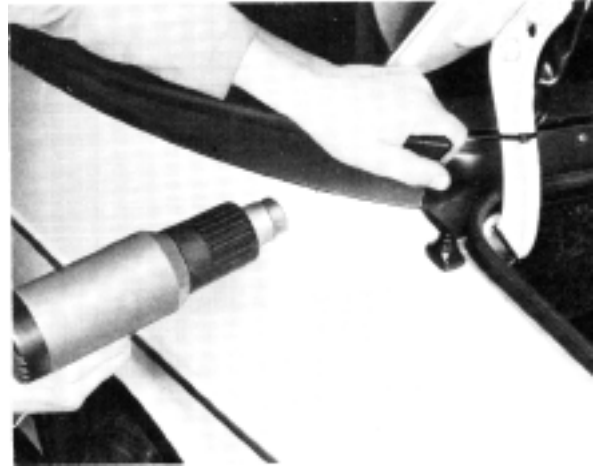

- 4 Release the spoiler section at the middle fastening.

Caution

The spoiler assembly must be eased off gently to prevent the paintwork being damaged.

- 5 Carefully lift off the spoiler assembly.
- 6 Save the cable in the rear mounting hole as this will be needed in the fitting of a new spoiler assembly (where applicable).

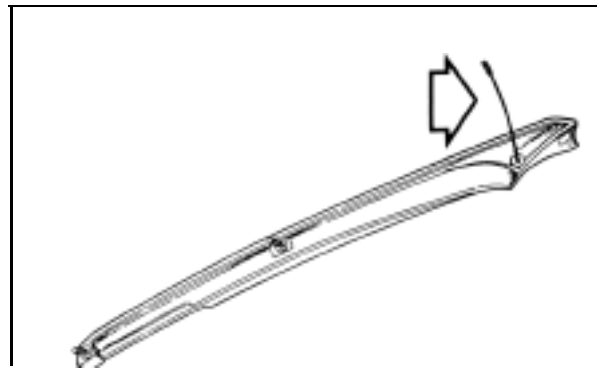

To fit

- 1 Carefully remove all traces of adhesive and dirt from the paintwork.



- 2 Remove all traces of old adhesive and dirt from the spoiler assembly.



- 3 Fit double-sided adhesive tape, part no. 78 74662, along the spoiler.

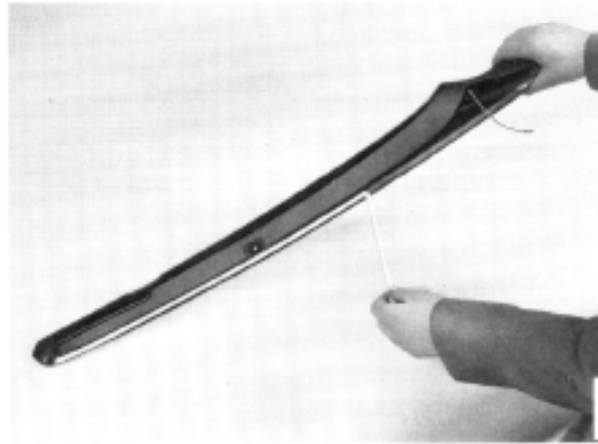

- 4 Make sure that the rubber washers and cable at the rear fastening are in place.

If a new spoiler assembly is being fitted, ~~the~~ rubber washers and cable must be transferred to the new one.

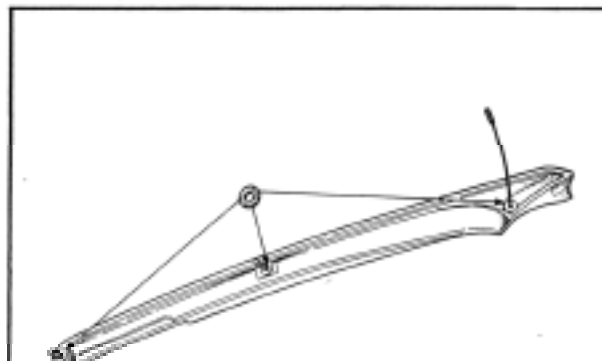

5 Press the spoiler section into the middle fastener.

6 Fit and tighten the wing nut on the rear stud.

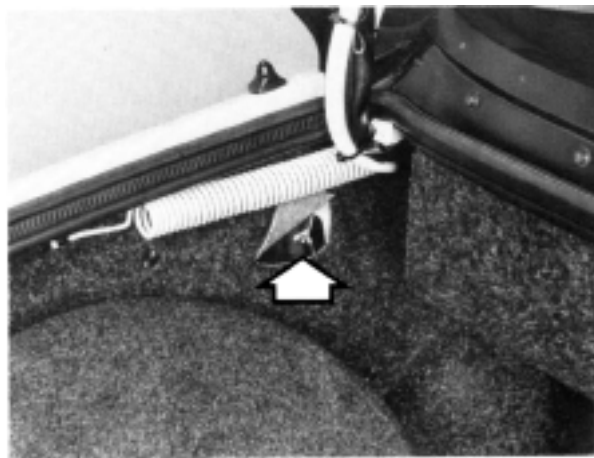

7 Fit and fasten the front nut



Rear assembly

To remove

- 1 Open the luggage-compartment lid and, where applicable, unplug the connector for the stoplight in the spoiler.
- 2 Remove the rubber plugs, followed by the spoiler retaining bolts and nuts.

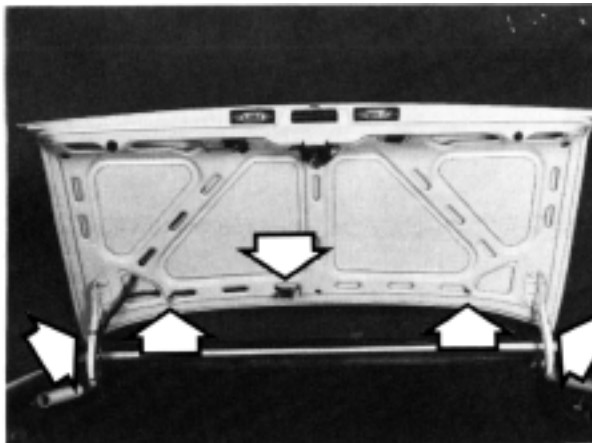

- 3 Use a heat gun to allow the tape to be pulled away. Take care not to apply too much heat as this can damage the paintwork or spoiler assembly.

Caution

The spoiler assembly must be eased off gently to prevent the paintwork being damaged.

- 4 Carefully lift off the spoiler assembly.



To fit

- 1 Remove all traces of old adhesive and dirt from the luggage compartment lid.



- 2 Remove all traces of old adhesive and dirt from the spoiler assembly.



- 3 Fit double-sided adhesive tape, part no. 78 74 662, along the spoiler.

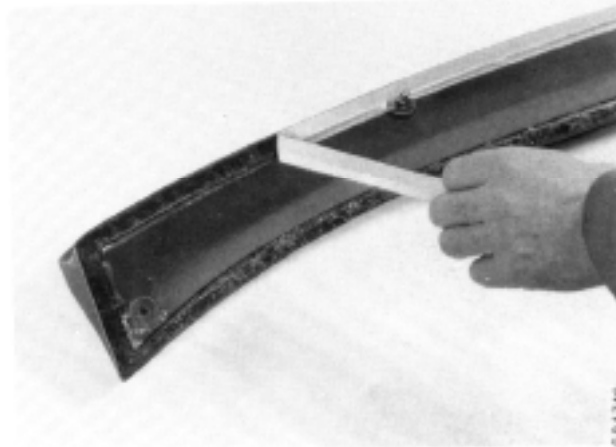

- 4 Apply Sikaflex 255 around the hole for the wiring to the stoplight.

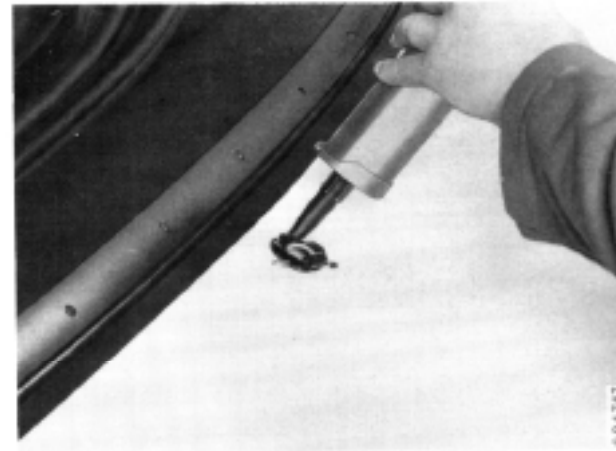

- 5 Lift the spoiler into position and, where applicable, feed the wiring loom for the stoplight through the hole in the lid.

- 6 Open the lid. Tighten the nuts and bolts and fit the rubber plugs.

Where applicable, plug on the connector for the spoiler stoplight.

