

- 32 Stretch the top fabric by pulling it down over the rails at the back and glue the top to the rails.

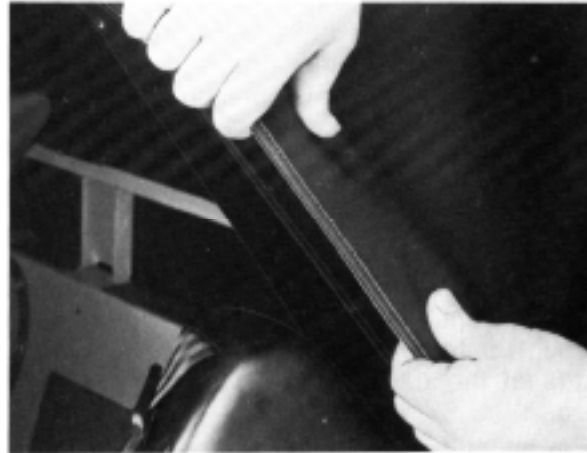

- 33 Apply adhesive along the outside edges of the rear seals.

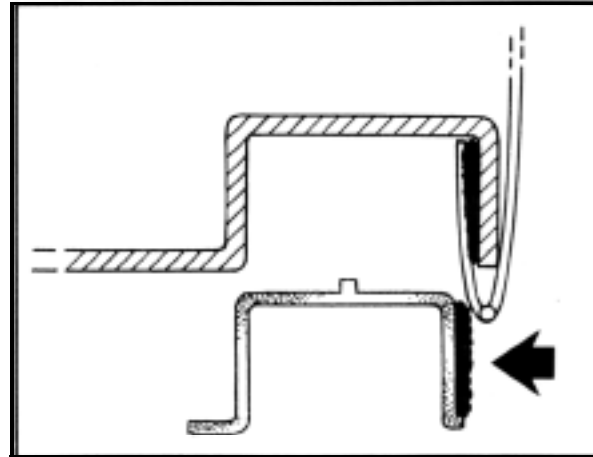

- 34 Place the rear seals in position, tighten the acorn nuts and fit the ties. Use cable ties, part no. (10) 79 71 899.

In order not to leave sharp edges that could damage the fabric, do not cut the ends of the ties but tuck them in instead.



35 Hang the rear screen from the strap and close the zip.

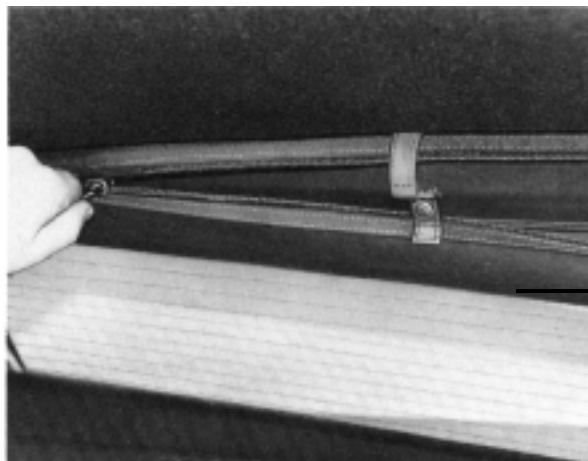

36 Place a protective cover over the luggage-compartment lid.

Using a drift, centre the top cover over the centre hole in the no. 4 crossmember. Stretch the fabric by pulling it towards the rear of the car and use a couple of staples to fix it into position.

---

#### N o t e

To ensure that the top cover is not pulled out of alignment, carry out each of the following steps (up to and including step 45) on both sides of the car before going on to the next step.

---

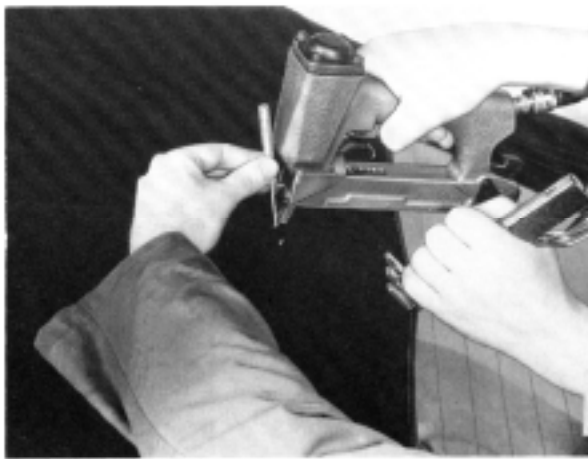

37 Stretch the top cover side flaps and ensure that the edge of the fabric is parallel with the edge of the rear screen. Secure the flaps with a couple of staples.

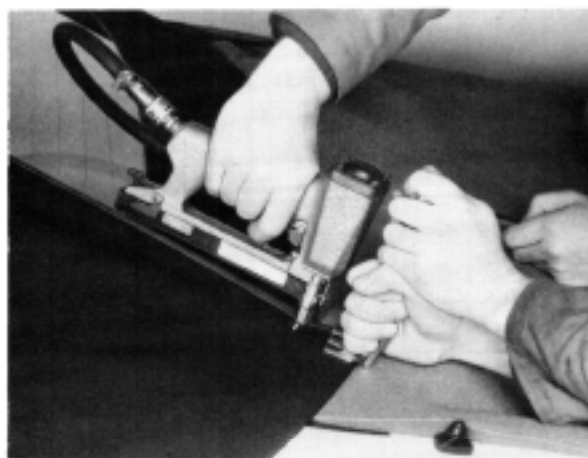

36 Stretch the top cover by pulling it down and towards the rear of the car at the side, and secure with a couple of staples.

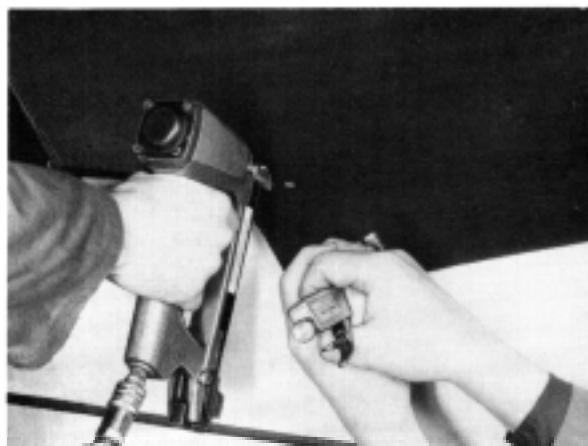

- 39** Remove the staples in the side panels, stretch the fabric again and use a couple of staples to hold it in place.

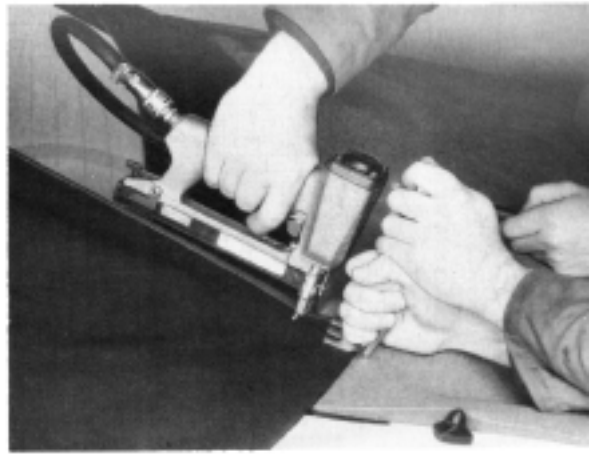

- 40** Remove the staples from the middle of the no. 4 crossmember, stretch the top fabric and secure by means of a couple of staples.

Stretch the cover by pulling it towards the rear of the car and staple it to the no. 4 crossmember. Stapling should be done along the centre-line between the seams, alternating between the right and left sides of the car.



- 41** Stretch the cover towards the rear on either side. Staple the fabric at the outboard ends of the no. 4 crossmember, outboard of the seams.

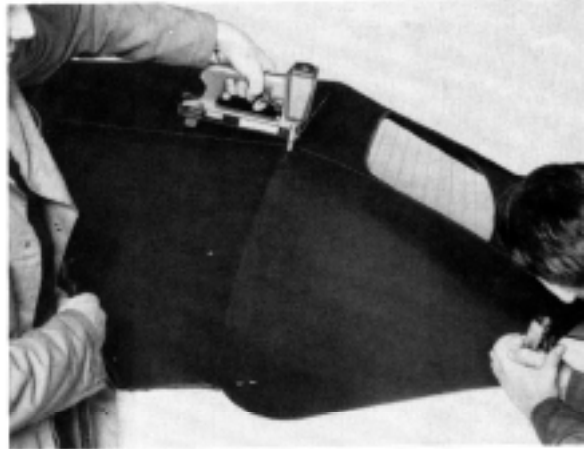

- 42** Remove the staples from the side panels, restretch the fabric and staple in position using a couple of staples.



- 43 Pull down the top cover side flaps to stretch them and staple the front part of the side flaps in position. Do not staple in the holes in the stretcher.

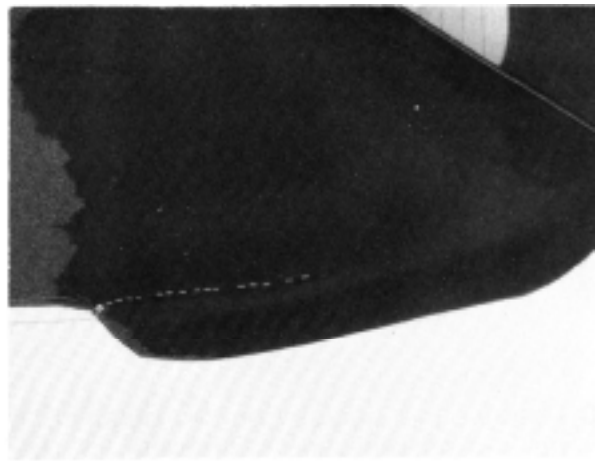

- 44 Pull down and stretch the inner fabric and staple in position.

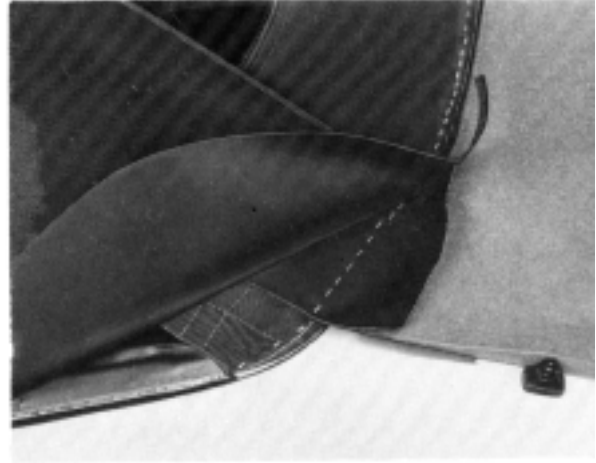

- 45 Pull down and stretch the side flaps, stapling them in the order shown.

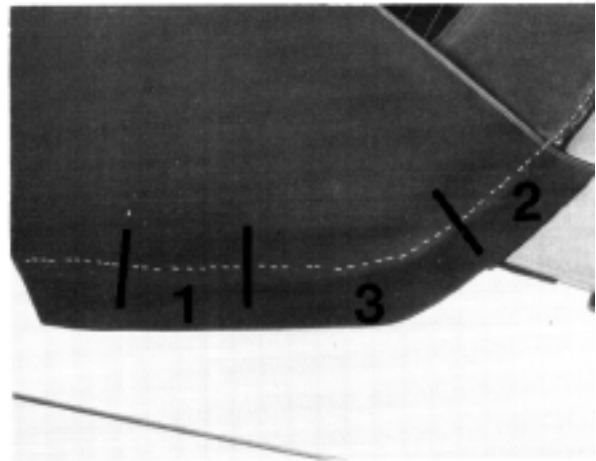

- 46 Apply a bead of adhesive along the line of staples in the no. 4 crossmember.

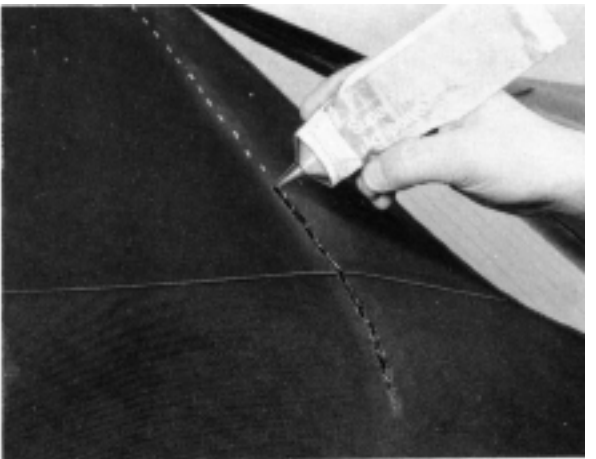

- 47 With the left and right marks correctly orientated, screw the feature-strip retainer into place on the no. 4 crossmember.

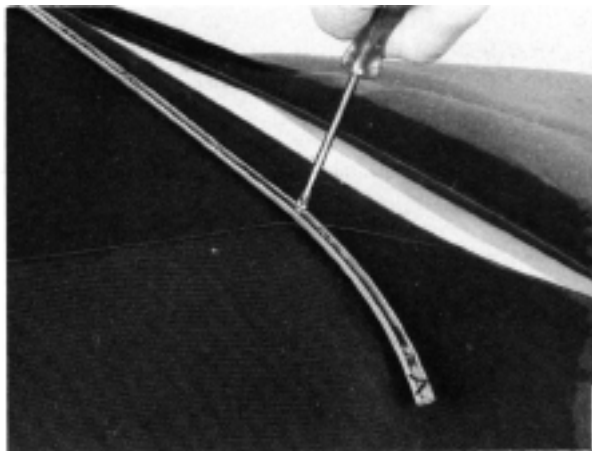

- 48 Apply a bead of adhesive along the retainer.

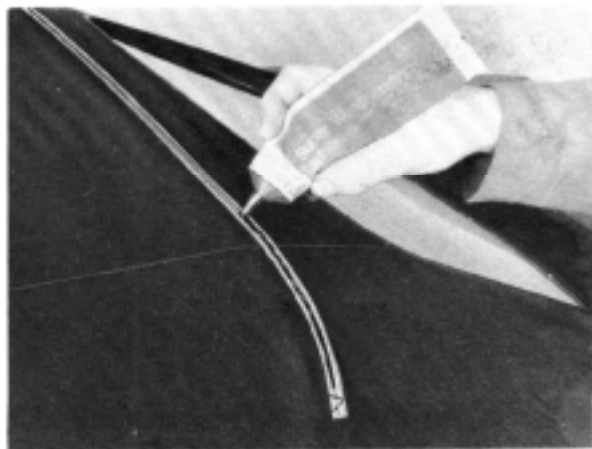

- 49 Press the feature strip into position and screw on the end caps.

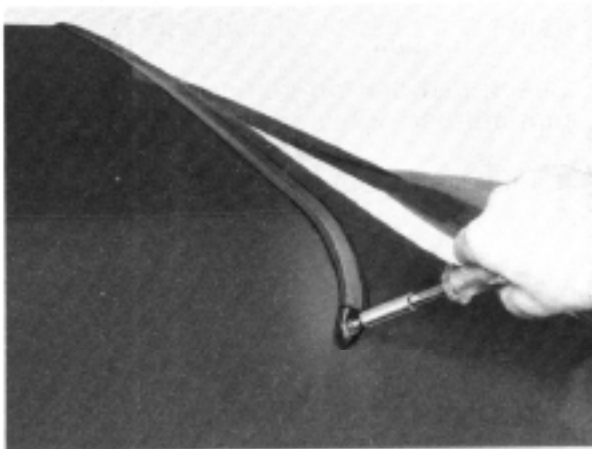

- 50 Trim the edges to remove surplus fabric.

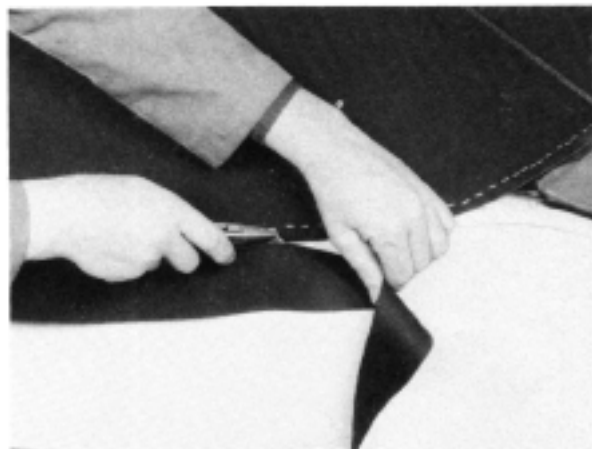

If the fabric is of Cambria make, use a heat gun to fuse the edges to prevent their fraying.

- 51 Pierce a hole in the fabric for subsequent insertion of the stud for the side section of the spoiler assembly.

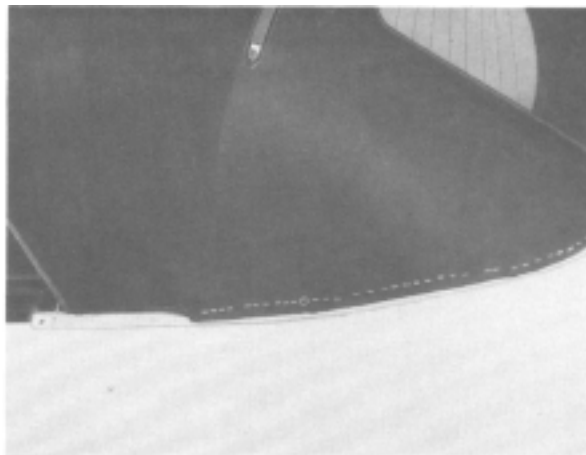

- 52 Screw the finisher strip into position at the tail end of the top.

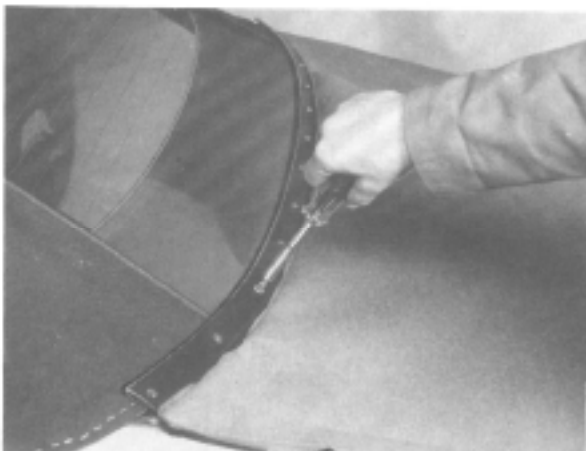

- 53 Remove the spacers from the windscreen frame and raise the top assembly.

Check that the top comes to rest 20 - 30 mm from the windscreen frame.

***Adjustment procedure in top spec and adjustment pdf***

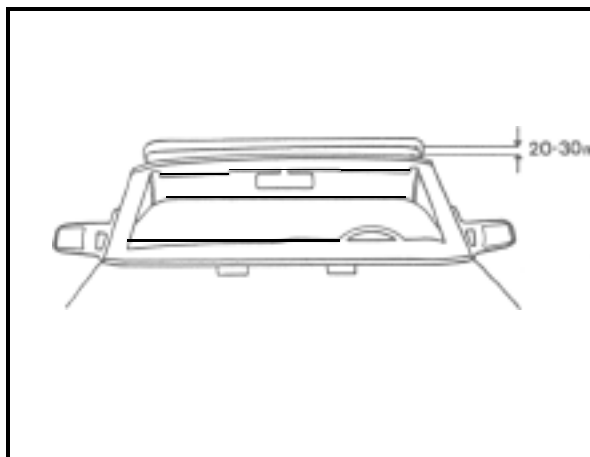

Check the adjustment of the latching hooks by latching the top in position and then pressing down on the front corners of the top. No play should be present.

***Adjustment procedure in top spec and adjustment pdf***

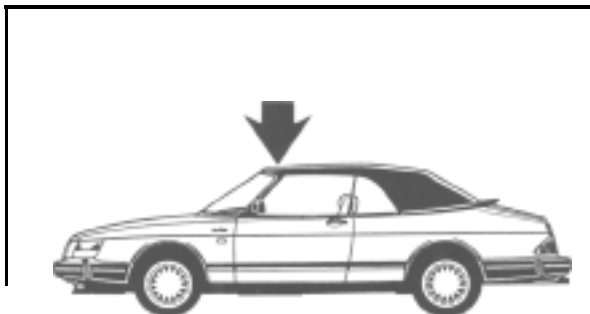

- 54 Adjust the position of the front seal snug against the door glass and tighten the nuts securing the seal retainer.

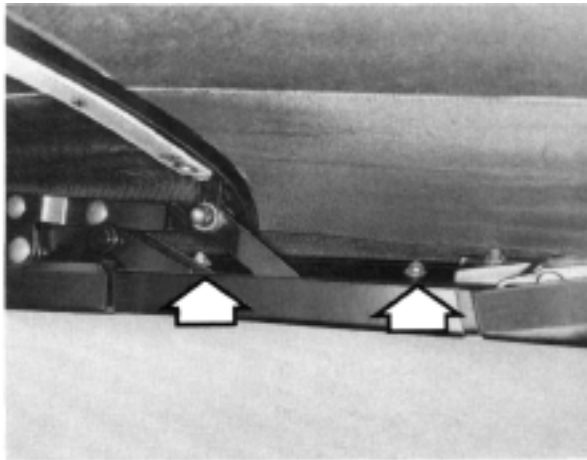

- 55 Fit the screws securing the anti-ballooning strips inside the pockets on the no. 2 and no. 3 crossmembers.

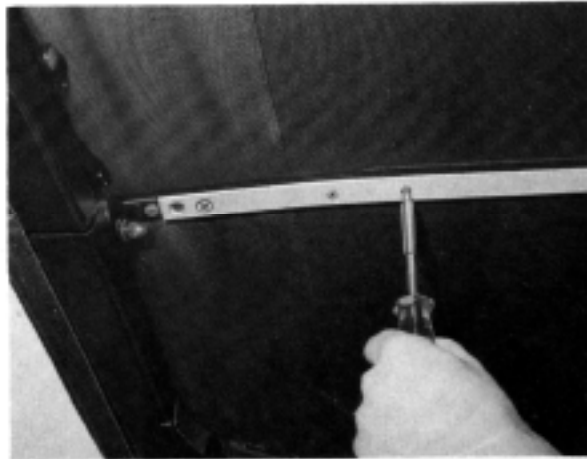

- 56 Fit the spoiler assembly ***See Spoiler pdf***

- 57 Fit the headlining ***See headlining pdf***