

Subject: Starting Problems Because of Sticking Fuel Pump Check Valve

Application: Certain 1990 900 and 9000 Models

CATEGORY	
Engine	
SECTION 2	PAGE 7
ISSUE 11/90-0051	CODE 234

The fuel pump check valve for the new "positive feed" ejector fuel pump is located in the fuel line elbow that fits into the top of the pump (see PSI 10/90-0032). On some cars equipped with the positive feed pump, the check valve may stick, resulting in longer engine cranking on restart because of the loss of fuel system rest pressure.

Cars affected:

- . 900: VIN L3007857-L3007862, L5003012-L5003921, L7021651-L7025524
- . 9000: VIN L1020824-L1022178, L2014948-L2015779

Check Valve Replacement Procedure

Verify that the check valve is faulty by checking the fuel system rest pressure. If the check valve is sticking, the rest pressure will rapidly drop to zero after the engine off is shut off.

1. Remove the trunk floor to gain access to the top of the fuel pump.
2. Remove the fuel supply fitting/check valve from the pump.

WARNING

Always observe the following safety precautions when working on the fuel system

- | **No Smoking!**
- | **Have A Fire Extinguisher Nearby.**
- | **Wear Eye Protection.**
- | **Work in A Well Ventilated Area (Use Vapor Extraction Equipment If Available.)**
- | **Avoid Prolonged Skin Contact With Fuel And Wear Suitable Gloves.**

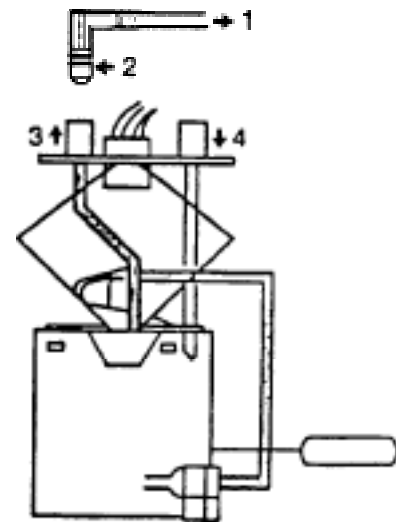

Figure 1. Pump with positive ejector

- 1) To fuel filter
- 2) Check valve
- 3) Delivery line
- 4) Return line

3. Remove the check valve by cutting the plastic fuel line 12-14 mm from the end of the line as shown in Figure 2.

Note

The fuel line must not be trimmed more than 14mm. If more than 14mm is removed, the line will be too short and will have to be replaced.

4. Fit special tool P/N 83 94 546 onto the fuel line as shown in Figure 3.
5. Press the new check valve, P/N 41 61766, into the fuel line (Figure 3).
6. Install two new O-rings (P/N 79 74 546) on the check valve.

Note

New O-rings must be used each time the check valve fitting is installed. These O-rings swell when exposed to fuel vapor and therefore cannot be re-used.

7. Reinstall the check valve into the top of the pump.
8. Start the engine and check that there are no fuel leaks.
9. Reinstall the trunk floor.

Warranty Information:

For Warranty Claims, use Failure Coding 24115-23-0-01-01. Time allowance is 0.6 hour straight time for 9000 and 0.4 hour straight time for the 900.

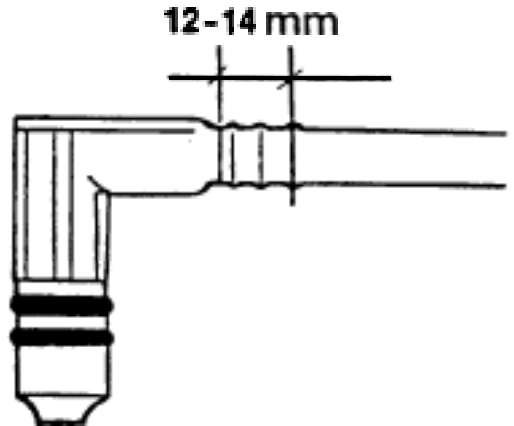

Figure 2. Cut off the old check valve, 12-14 mm from the end.

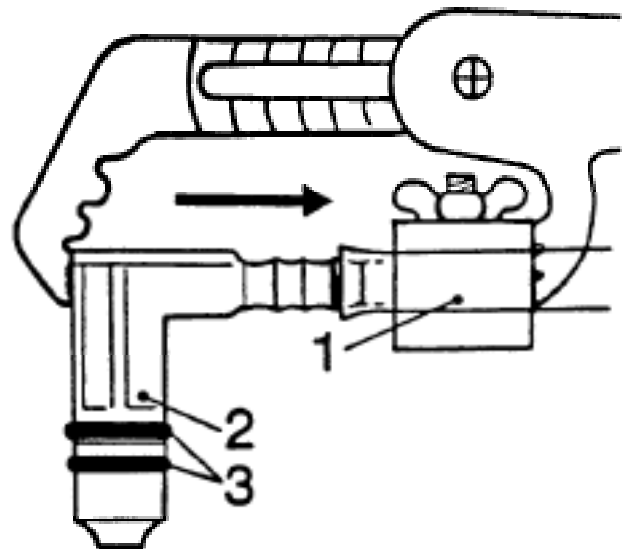

Figure 3. Fitting a check valve
1) Special tool P/N 83 94 546
2) Check valve P/N 41 61 766
3) Two O-rings P/N 79 74 546